



— MODEL — **CFF18T-H2**

Flanged Float Control for Fuel-Water Separators with Manual Tester



- Fully automatic operation
- Conforms to rigid military specifications
- No packing glands; requires no lubrication
- Compact and simple to install
- No mechanical linkage or electrical connections
- No exposed moving parts or stuffing boxes

The Cla-Val Model CFF18T-H2 Fuel-Water Separator Control automatically operates the fuel discharge valve and the water drain valve of fuel-water filter separators. It is mounted to a flange on the side of the separator vessel in the sump. The float responds to changes in level of the interface surface of the water and fuel inside the sump area. The pilot valve is a precision-lapped rotary disc, plate type valve. The CFF18T-H2 Control automatically performs the following functions:

1. Opens the water drain valve (Model 100AF) to remove accumulated water that exceeds the safe level in sump area.
2. Closes the fuel discharge valve (Model 413-01 or 40-28 AGS) should the water level rise to the upper float level. The water drain valve remains open.
3. Re-opens the fuel discharge valve when the water in the sump lowers to a safe level.
4. Closes the water drain valve when the level reaches a low point in the sump.
5. Provides easy manual testing of fuel-water separator control function with simple plunger-type mechanism spring loaded to return to normal operating position.

The CFF18T-H2 Control is used with aviation gasoline, jet fuels, motor fuels, diesel, solvents and other petroleum products. This control has a variable pressure rating depending on lever arm length and is suitable for handling liquids with a specific gravity of 0.90 or less.

DIMENSIONS (In Inches)

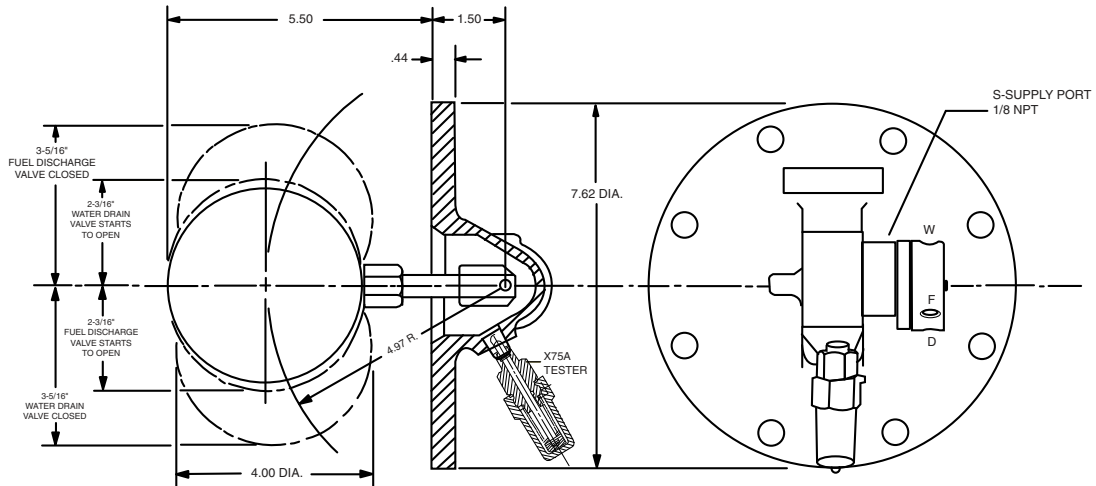

TYPICAL APPLICATIONS

WITH WATER DRAIN VALVE, WITH PRODUCT RECOVERY TANK

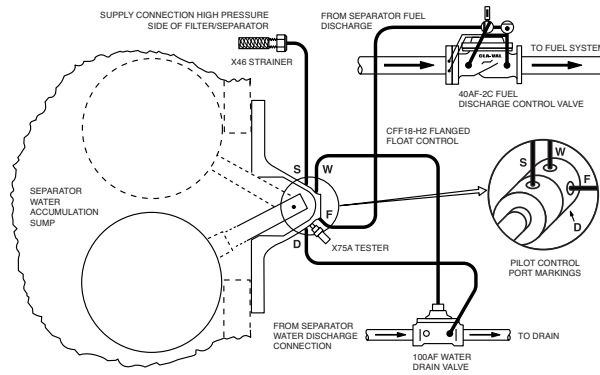

WITHOUT WATER DRAIN VALVE, WITH PRODUCT RECOVERY TANK

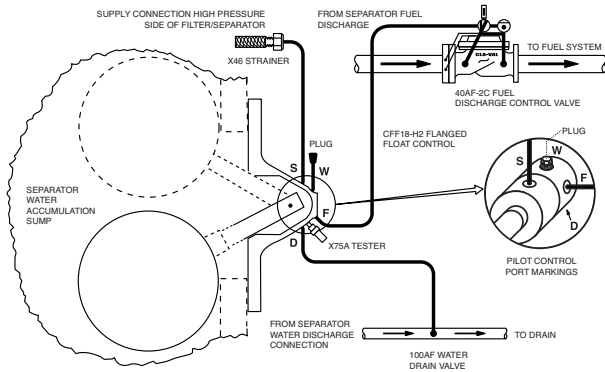

WITHOUT WATER DRAIN VALVE OR PRODUCT RECOVERY TANK

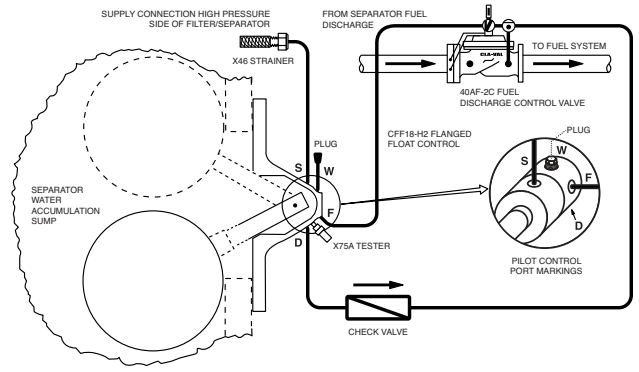

FLOAT POSITION	WATER DRAIN VALVE	FUEL DISCHARGE VALVE
DOWN	CLOSED	OPEN
CENTER	OPEN	OPEN
UP	OPEN	CLOSED

SPECIFICATIONS

MILITARY

MIL-F-254, MIL-F-15618 and MIL-F-27629B (USAF)

TEMPERATURE RANGE

32°F to 180°F

FLUIDS

Water and light petroleum products, MIL-F-5572, MIL-J-5624 and MIL-F-5616

PRESSURE RATING

225 psi maximum

MATERIALS

Flange:
Stainless Steel ASTM A296
Aluminum 356T6

Pilot Housing:
Stainless Steel Type 303
ASTM A296

Pilot Valve:
Stainless Steel Bar AISI 303

Float and Float Arm:
Stainless Steel AISI 303
1/8" N.P.T.

CONTROL PORT CONNECTION SIZE

Note: Available without X75A Tester as Model CFF18-H2.

PURCHASE SPECIFICATIONS

This control shall be specifically designed to respond to changes in level of the interface surface of the water and fuel inside the water sump of fuel-water separator and shall operate the diaphragm actuated water drain valve and fuel discharge valve. The actuating fluids on the diaphragms of both the water drain valve and the fuel discharge valve shall be relieved through the pilot valve to the water drain valve.

The float control shall consist of a pilot valve mounting flange and float assembly. The float shall be designed to sink in fuel and float in water. The pilot shall be a precision-lapped, rotary disc plate type valve. Porting arrangement shall permit control of a water drain valve and a fuel discharge valve. A manual plunger-type actuator shall be supplied to activate float mechanism for testing.

This control shall be similar in all respects to the Model CFF18T-H2 Flanged Float Control as manufactured by Cla-Val, Newport Beach, California, or approved equal.



CLA-VAL

E-CFF18T-H2 (R-03/2021)

CLA-VAL

1701 Placentia Avenue • Costa Mesa, CA 92627

800-942-6326 • Web Site: www.cla-val.com • E-mail: info@cla-val.com

CLA-VAL CANADA

4687 Christie Drive
Beamsville, Ontario
Canada L0R 1B4
Phone: 905-563-4963
www.cla-val.com
E-mail sales@cla-val.ca

CLA-VAL EUROPE

Chemin des Mésanges 1
CH-1032 Romanel/
Lausanne, Switzerland
Phone: 41-21-643-15-55
www.cla-val.ch
E-mail: info@cla-val.ch

CLA-VAL UK

Dainton House, Goods Station Road
Tunbridge Wells
Kent TN1 2 DH England
Phone: 44-1892-514-400
www.cla-val.ch
E-mail: info@cla-val.co.uk

CLA-VAL FRANCE

Porte du Grand Lyon 1
ZAC du Champ du Périer
France - 01700 Neyron
Phone: 64-39644860
www.cla-val.ch
E-mail: info@cla-val.ch

CLA-VAL ASIA PACIFIC

45 Kennaway Road
Woolston, Christchurch, 8023
New Zealand
Phone: 64-39644860
www.cla-valpacific.com
E-mail: info@cla-valpacific.com