



— MODEL — **100AF**

3/4" & 1" Sizes

Fueling Drain Valve



- No lubrication required
- No packing glands; leak-proof service
- Fully supported diaphragm has long life
- Drip tight closure
- Removable seat ring (1" & Larger)
- Single seat, resilient disc assures tight seal
- Simple design, with few moving parts

DESCRIPTION

The Cla-Val Model IOOAF Fueling Drain Valve is a diaphragm actuated, hydraulically operated globe pattern valve. It is installed in the drain line from the water accumulator sump of FueVWater Separators. It is controlled by the Float Control valve which applies operating pressure above the diaphragm when the Fueling Drain Valve is to close and relieves pressure to the atmosphere when the valve is to open. If diaphragm becomes damaged, valve closes tight.

INSTALLATION

1. Before valve is installed, pipe line should be flushed of all chips, scale and foreign matter.
2. Preferred installation position is horizontal with cover up. However, vertical or inverted installation is acceptable.
3. Place valve in the line with flow through the valve in the direction indicated on inlet plate or by flow arrow.
4. Tighten cover screws.
5. After the valve is installed and the system is first pressurized, vent air from the cover chamber and tubing by loosening fittings at all high points.

MAINTENANCE

Model IOOAF Valves require no lubrication or packing and a minimum of maintenance.

Disassembly

The inspection or maintenance of the IOOAF Valve can be accomplished without removal from the line. After pressure has been shut off and the pressure released from the valve and cover chamber, unscrew cover screws and remove cover, spring and diaphragm assembly. Check disc retainer assembly for excessive wear or embedded particles.

Reassembly

To reassemble reverse the order of disassembly.

SPECIFICATIONS

MILITARY	MIL-F-254D
SIZES	3/4", - 1" Other sizes available
PRESSURE RATING	<i>maximum:</i> 400 psi
TEMPERATURE RANGE	32° F. to 180° F.
FLUIDS	Water
STANDARD MATERIALS	<i>valve body and cover:</i> Bronze ASTM B-62 <i>valve trim:</i> Brass <i>diaphragm and disc:</i> Fuel resistant synthetic rubber
OTHER MATERIALS AVAILABLE	Aluminum, or Stainless Steel



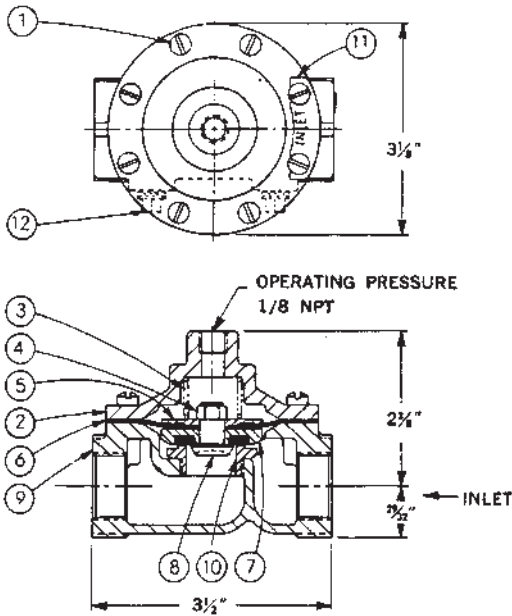

**3/4" MODEL 100AF
STOCK NO. 61097**

ITEM	DESCRIPTION	QUAN. PER UNIT
1.	Cover Screw 10-32 x 3 1/2	8
2.	Cover	1
3.	Spring	1
4.	Stem Nut 3/8-24	1
5.	Dia phragm Washer	1
6.	Dia phragm	1
7.	Disc Retainer Assembly	1
8.	Disc Guide & Stem	1
9.	Body	1
10.	Seat	1
11.	Nameplate	1
12.	Body Plug 1/4 NPT	2

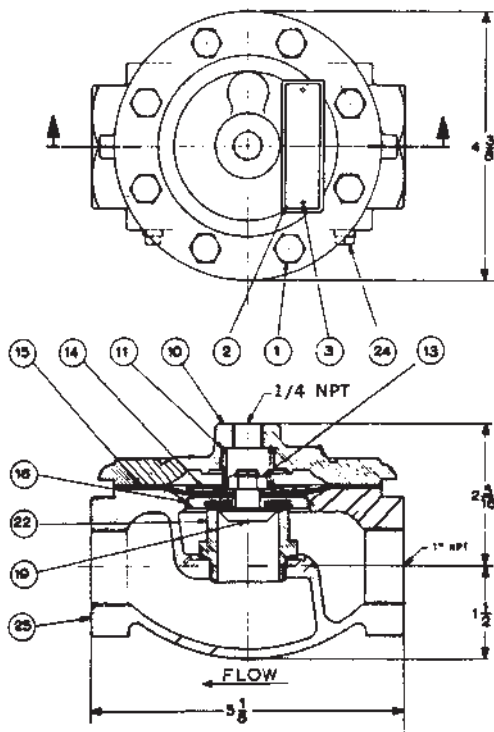

**1" MODEL 100AF
STOCK NO. 38367**

ITEM	DESCRIPTION	QUAN. PER UNIT
1.	Cover Screw 1/4-20 X 7/8	8
2.	Nameplate	1
3.	Nameplate Screws	2
4.	Spring	1
10.	Stem Nut 3/8-24	1
11.	Diaphragm Washer	1
13.	Diaphragm	1
14.	Disc Retainer Assembly	1
15.	Disc Guide	1
22.	Seat	1
24.	Body Plug 1/4 NPT	2
25.	Body	1



CLA-VAL

PO Box 1325 Newport Beach CA 92659-0325
Phone: 949-722-4800 • Fax: 949-548-5441

CLA-VAL CANADA

4687 Christie Drive
Beamsville, Ontario
Canada L0R 1B4
Phone: 905-563-4963
Fax: 905-563-4040

CLA-VAL EUROPE

Chemin des Mesanges 1
CH-1032 Romanel/
Lausanne, Switzerland
Phone: 41-21-643-15-55
Fax: 41-21-643-15-50

©COPYRIGHT CLA-VAL 2014 Printed in USA
Specifications subject to change without notice.

www.cla-val.com

Represented By: