

Fuelling products

Bottom loading coupler

F214

F214 Bayonet flange connection nonpressure control coupler



The Meggitt 3-inch bottom loading coupler is designed for the use in bulk plant system where the standard 4 inch API F228 coupler is too large. The F214 coupler mates with F429 adapter and has a unique snap - on pull - off connection action not used on the larger relatives. The coupler is available with 2, 2.5 and 3-inch female pipe threads or a 3-inch TTMA flange.

Notes:

1. Various F582 and F584 swivel assemblies will mate the F214 coupler to provide coupler rotation
2. Older style F214 with spring loaded sleeves may be converted to current wave washer design by ordering KITF214-102

Key Features

- Reduced sized API style design
- Snap-on, pull- off connection - one hand operation
- Full interlock safety
- Compact, low weight, rugged design
- Low pressure drop
- Capable of 8-inch center to center multi - adapter installation
- Suitable for on-truck swing - hose delivery systems (seetech section)
- 200 PSI proof pressure
- Mates Meggitt F429 adapter
- Lightweight, rugged aluminum construction
- Standard seals recommended for all commercial automotive and aircraft fuels - Viton seals available

Meggitt Control Systems

Our product competencies & services:
Aerospace valves | Thermal management solutions | Environmental control systems | Electro-mechanical products
Ground fuelling products | Energy products | Aftermarket services

MEGGITT
smart engineering for
extreme environments

Fuelling products

Bottom loading coupler

F214

Key Dimensions

F214

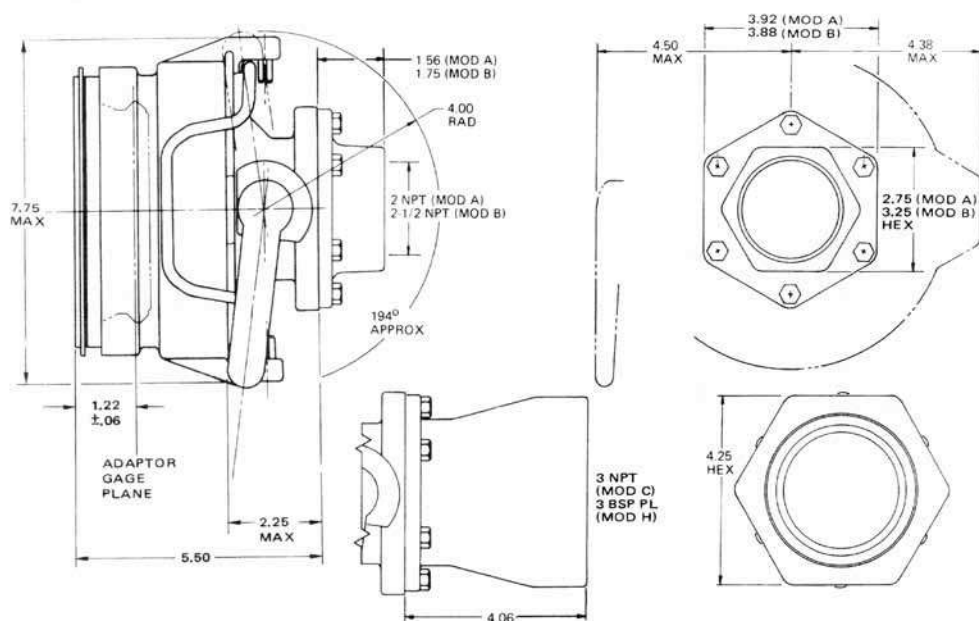

Contact

Meggitt North Hollywood

12838 Saticoy Street
North Hollywood
California 91605-3505
USA

Tel: (818) 765-8160

Fax: (818) 759-2194

www.meggitt.com

Meggitt Control Systems

Our product competencies & services:

Aerospace valves | Thermal management solutions | Environmental control systems | Electro-mechanical products
Ground fuelling products | Energy products | Aftermarket services

MEGGITT
smart engineering for
extreme environments